

AIR HYDRAULIC DRILLING UNIT

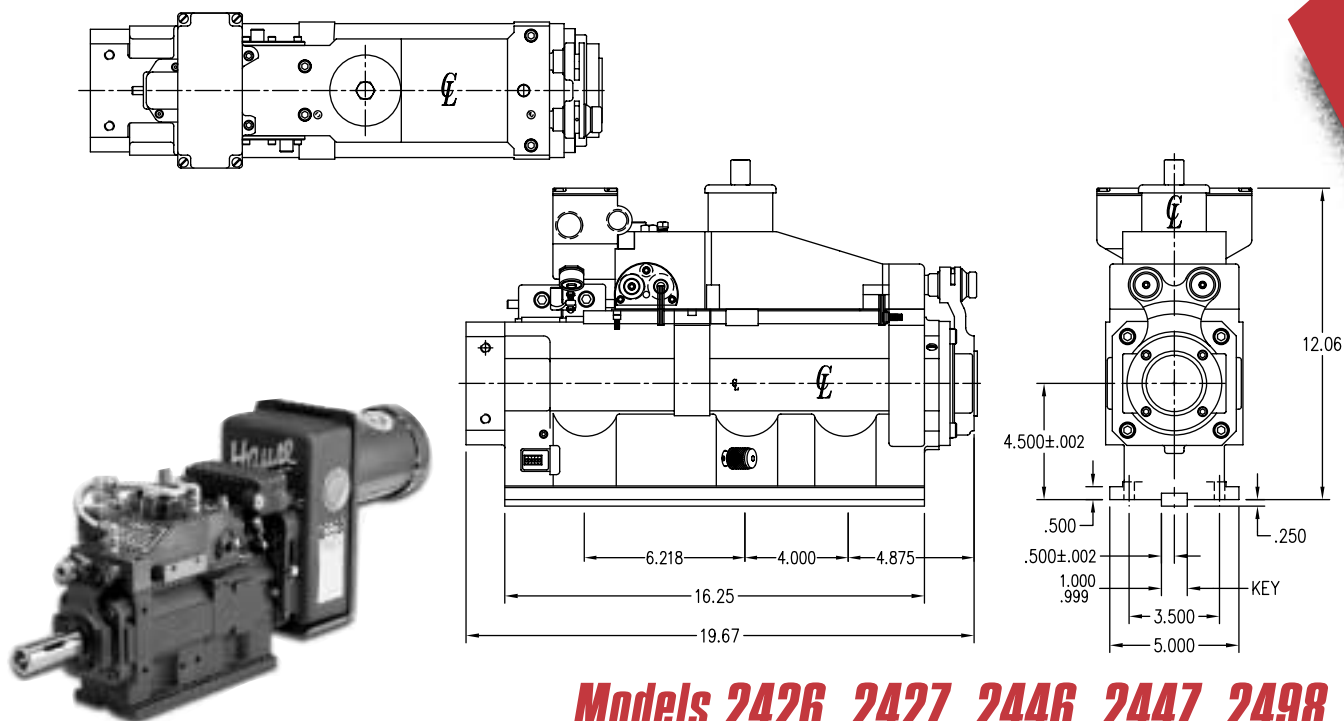

Models 2426, 2427, 2446, 2447, 2498

Specifications (Unit: inch)

Model No.	Thrust Adv./Ret. @ 80 psi	Stroke	Quill Dia.	Max. Spindle Speed	Min. Spindle Speed	Retract Feed	Oil Filler Style
2426	680/280	4"	3.500"	6000	120	Yes	Pressurized
2427	680/280	4"	3.500"	6000	120	No	Pressurized
2446	680/280	4"	3.500"	6000	120	Yes	Pressurized
2447	680/280	4"	3.500"	6000	120	No	Pressurized
2498	680/280	4"	3.500"	6000	120	Peck Feed	Pressurized

Customizing A Hause Unit To Your Specs

Most Hause power feed units can be customized to best fit the needs of your unique applications. Using the worksheet at the back of this catalog and the information found on pages 36 - 49, you can spec out the Hause unit of your choice.

Model	Spindle	Drive	Belt/Pulley	Motor	Belt Housing	Special
2427	- BE	- A	- A	- N	- C2	-
	Pgs. 36-37	Pgs. 38-39	Pgs. 40-41	Pgs. 42-44	Pg. 45	Pgs. 46-49

Example: 2427-BE-A-A-N-C2 This code specifies an Air Hydraulic Drilling unit (Model No. 2427) with a 4" stroke. Accessorizing this unit is a 1-1/16" Adjustable Adapter Spindle, In-line Shaft Drive, 5-Step "3V" Section Pulley, a 2 HP (1800 RPM) Nema "C" Flange Mounted Motor, mounted to the right side on an Extended Belt Housing.

Features

- Concentric construction.
- Pressure compensating feed valves.
- Belt housing/position choices.
- Various spindle and drive choices.
- Pulley and RPM choices.

Note: Models 2426-2427 are for horizontal type applications and Models 2446-2447 are for vertical type applications. The 2498 can be used vertically or horizontally.

Feed rates

Adv: Adjustable from 3/8" to 125" per minute.

Ret: Adjustable from 3/8" to 125" per minute.

Rapid travel 1000 I.P.M. approx.

Any questions or to place an order, contact:
 Hause Machines, Inc • 809 S. Pleasant St. • Montpelier, OH 43543
 800-932-8665 • 419-485-3158 • Fax 419-485-3146
 www.hausemachines.com