

COMPLETE BASIC UNIT SUB-ASSEMBLIES**Series A6—"Hydraulic"**

Ref.: Dwg. 21776-01, 4", 6", and 10" Strokes

GENERAL DESCRIPTION

The nine assemblies that compose a complete basic unit are shown detached with their relative positions indicated. Options are shown or listed on three assemblies. Selection of options is based on the application. Their features and uses are described on separate bulletin sheets.

The spindle assembly, drive, belt housing, and motor are accessories and not part of the basic unit and, therefore, are omitted.

CODE 1. HOUSING ASSEMBLY

This is the frame and enclosure. It supports all components and sub-assemblies of the basic unit. Belt housing assemblies are attached to the rear and spindle supports are attached to the front face. A stroke control actuator and a stroke adjustment assembly are removable and included in this assembly. (Bul. 21727-00.)

CODE 2. CYLINDER ASSEMBLY

The hydraulic cylinder surrounds the central quill section which carries the spindle assembly in its stroke path. It is inserted and removed from the housing in cartridge form as shown. (Bul. 21728-00.)

CODE 3. PLUG ASSEMBLY

The plug assembly functions as the name implies, closing off openings in the housing and manifold. (Bul. 21815-00.)

CODE 5. CAM BAR COVER

This consists of two cylindrical enclosures for the cam bars and operator's safety. They are mounted between the front of the manifold and the housing. (Bul. 20680-0.)

CODE 6. FRONT BRACKET ASSEMBLY

This bracket secures the spindle bearings in front and strokes the cam bars. An integral, short cylindrical pilot extension centralizes non-rotating quill attachments. (Bul. 21720-01.)

CODE 7A. MANIFOLD ASSEMBLY — ADVANCE STROKE CONTROL ONLY**CODE 7B. MANIFOLD ASSEMBLY — ADVANCE AND RETRACT STROKE CONTROL**

A manifold mounted on top at the rear of the housing is the enclosure for the hydraulic control section of the unit. It contains the valves that regulate the flow of oil to govern the spindle stroking motion. As the title implies, they are furnished for one-way and two-way control with one and two sets of valves. (Bul. 21729-00.)

CODE 8A. CAM BAR ASSEMBLY — ADVANCE STROKE CONTROL ONLY**CODE 8B. CAM BAR ASSEMBLY — ADVANCE AND RETRACT STROKE CONTROL**

Cam bars are mounted to the front bracket and guided thru corresponding holes in the forward end of the housing. They are furnished plain cylindrical and with spiral groove. A spiral cut bar engages the corresponding lever assembly to operate a plunger and produce valve action in the manifold. A plain cylindrical bar functions only as a guide. A pair of spiral cut bars and their adjusting knobs are required for advance and retract stroke control. (Bul. 21722-00.)

CODE 9A. LEVER ASSEMBLY FOR ADVANCE STROKE CONTROL ONLY**CODE 9B. LEVER ASSEMBLY FOR ADVANCE AND RETRACT STROKE CONTROL**

The block acts as a fulcrum and is mounted to a mating step on the housing. The forward end of the shaft mounts on a stud. The levers are links between the cam bars and their corresponding plunger assemblies in the manifold. One only is required for advance stroke control. (Bul. 21730-00.)

CODE 10. RETRACT ACTUATOR ASSEMBLY — SWITCH DEPTH CONTROL

A lever mounted on the shaft of the stroke control actuator transfers its motion to a switch attached to the enclosure, which when operated supplies an electric signal to a relay (not included). This in turn provides the electric signal to the directional valve (not included). The switch box design provides mountings for additional switches, solenoid pilot valves and includes terminal strips for wiring connections. (Bul. 21763-00.)

GENERAL MAINTENANCE

The construction and arrangement of assemblies that make up a basic unit affords considerable freedom of choice in assembly and service work. Complete maintenance by the cartridge renewal method is within the capability of relatively inexperienced personnel.

A complete assembly job starting with code 1 housing should begin by removal of the stroke control actuator, followed by installation of the code 2 cylinder assembly. Then re-mount the actuator and check for freedom of movement with the stroke control and proper timing of the mating gear on the position indicator. Following this, the normal sequence would be code nos. 3, 5, 7, 10, 8, 6, 9.

In disassembly or service work, the following assemblies can be removed without interference in any sequence: code nos. 6, 7, 8, 9, 10. Remove the stroke control actuator before code 2 cylinder assembly.

For the remaining assemblies, code 7 must precede code 5 and code 3.

Complete sets of seals are available for users with adequate means and personnel who wish to do their own repair work. Generally, space assemblies code nos. 2 and 7 can be most convenient because of the ease and speed of replacement, and their repairs can be made at leisure.

For complete seal renewal, order service kit seals no. 21743-01.

Information in detail for this work is given in the individual sub-assembly bulletins.

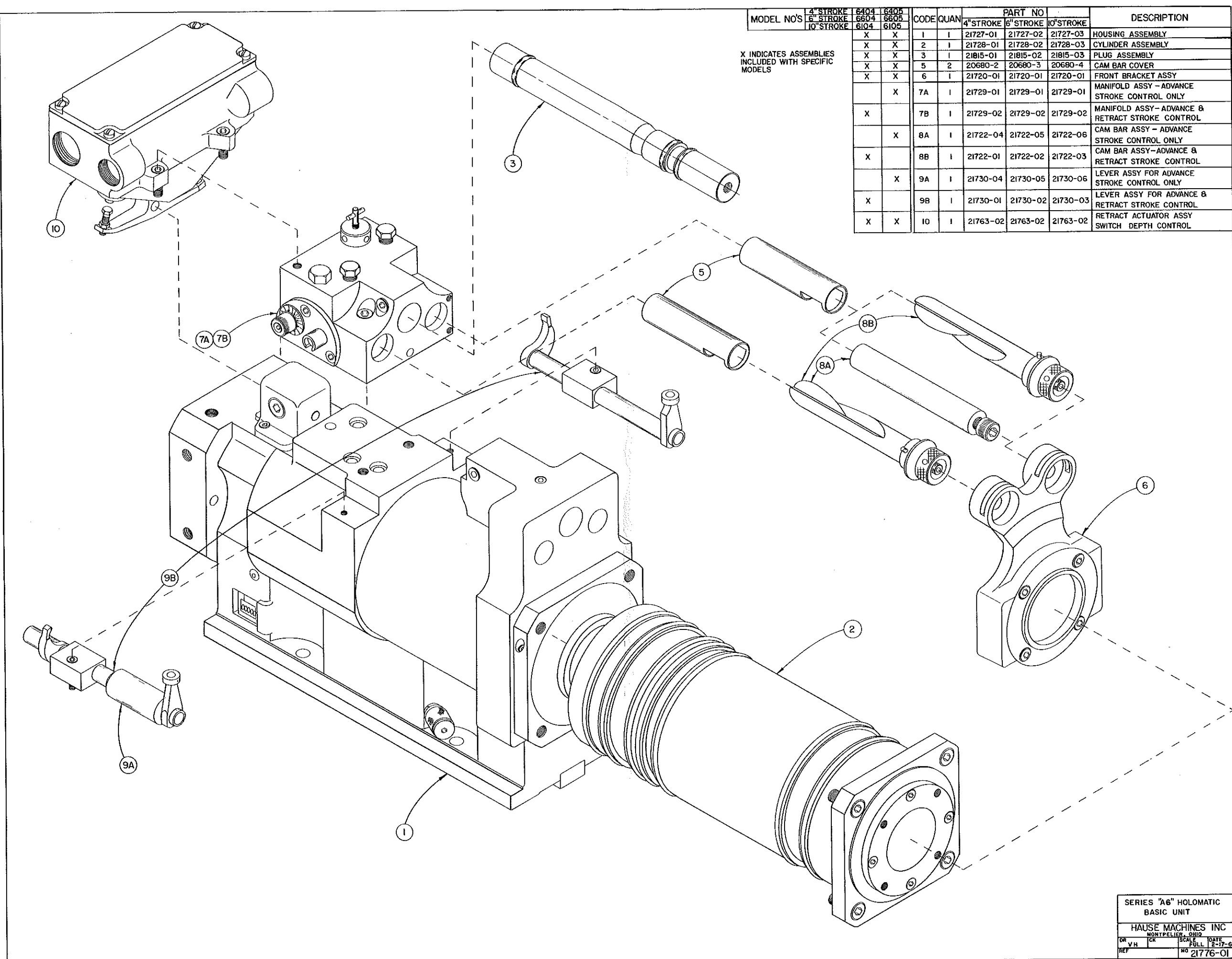

MODEL NO'S	4" STROKE		6" STROKE		PART NO			DESCRIPTION
	6404	6604	6104	6105	4" STROKE	6" STROKE	10" STROKE	
X	X				21727-01	21727-02	21727-03	HOUSING ASSEMBLY
X	X				21728-01	21728-02	21728-03	CYLINDER ASSEMBLY
X	X				21815-01	21815-02	21815-03	PLUG ASSEMBLY
X	X				20680-2	20680-3	20680-4	CAM BAR COVER
X	X				21720-01	21720-01	21720-01	FRONT BRACKET ASSY
	X				7A	21729-01	21729-01	MANIFOLD ASSY - ADVANCE STROKE CONTROL ONLY
X					7B	21729-02	21729-02	MANIFOLD ASSY - ADVANCE & RETRACT STROKE CONTROL
	X				8A	21722-04	21722-05	CAM BAR ASSY - ADVANCE STROKE CONTROL ONLY
X					8B	21722-01	21722-02	CAM BAR ASSY - ADVANCE & RETRACT STROKE CONTROL
	X				9A	21730-04	21730-05	LEVER ASSY FOR ADVANCE STROKE CONTROL ONLY
X					9B	21730-01	21730-02	LEVER ASSY FOR ADVANCE & RETRACT STROKE CONTROL
X	X				10	21763-02	21763-02	RETRACT ACTUATOR ASSY SWITCH DEPTH CONTROL

X INDICATES ASSEMBLIES INCLUDED WITH SPECIFIC MODELS

SERIES "A6" HOLOMATIC
BASIC UNIT
HAUSE MACHINES INC
MONTPELIER, OHIO
DATE 2-17-69
SCALE FULL
NO 21776-01