



Drilling Unit FD55-80



■ Specification

Pneumatic Pressure	55 ~ 85 P.S.I
Drilling Capacity	5/16" (steel) 70 P.S.I
Chuck Type	ER-20-1/2", JT6-1/2"
Power	0.5HP-2p or 4p, 1HP-2P or 4P, 200V/440V-60HZ
Max. Revolution/Minute	5,000rpm
Weight	84 lb
Overall Stroke	3"
Drilling Stroke	1" or 2"
Cylinder Diameter	2.5"
Cylinder Area	Forward 3.74 IN ² , Backward 1.8 IN ²
Transmission Pulley	V-Shape 201J, 220J
Thrust Force	265 lb @ 70P.S.I

■ Consumption Parts

Spindle Bearing	a. 6004Zx2, 6003ZZx1
	b. 7004x2, 7003x1
Pulley Bearing	6005ZZx1, 6205ZZx1
O-Ring for Front Cover	P-50x1, G-65x1, DKB-50, 62.7x1
O-Ring for Piston	OSY-63x2
O-Ring for Rear Cover	P-30x2, G-40x1, G45x1

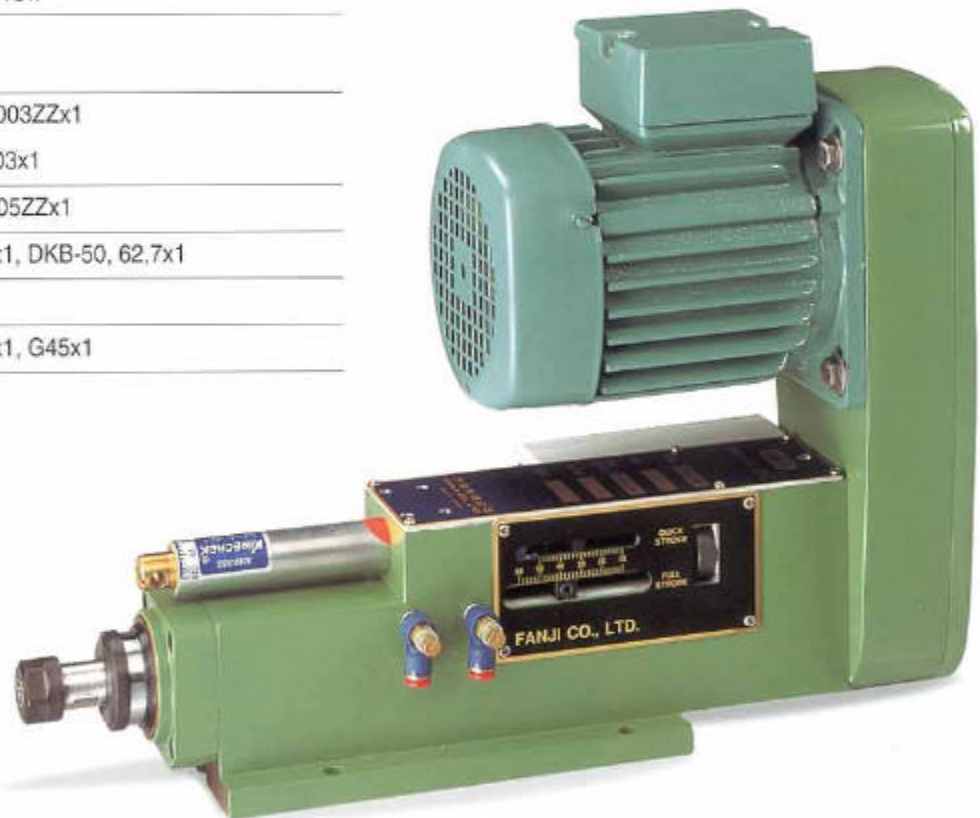

Hause Machines, Inc.
809 S. Pleasant St.
P.O. Box 229
Montpelier, OH 43543

Phone 419-485-3158
Toll Free 800-932-8665
Fax 419-485-3146
E-mail hause@bright.net
Web Page www.hausemachines.com

- RPM and chuck type should be specified when placing order
- There are two drilling strokes, 1" and 2", to choose from
- Equipped with internal electrical micro switch.
- Stroke and stopper adjustment can be done in one combined step.
- Motor and pulley location can be mounted around the circle in 45 degree interval.



Drilling Unit FD55-80

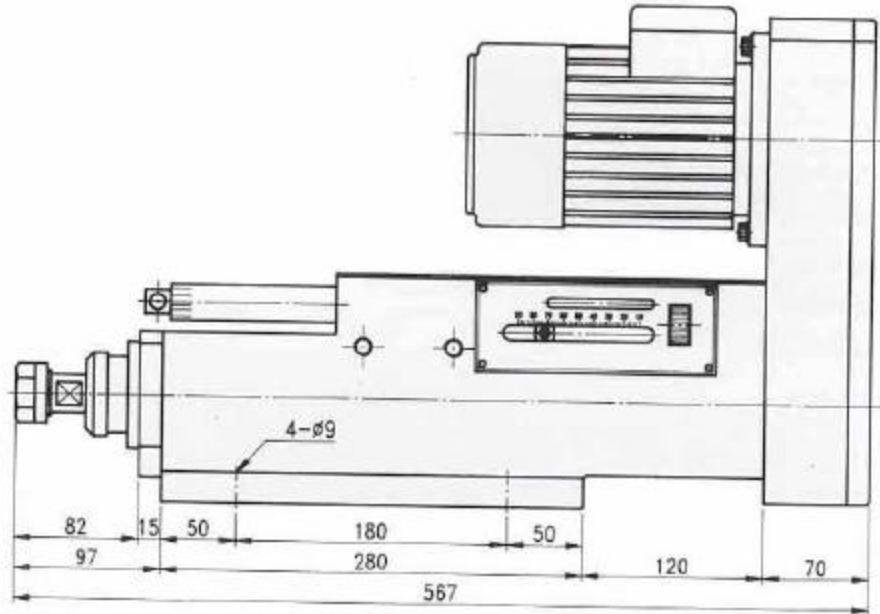
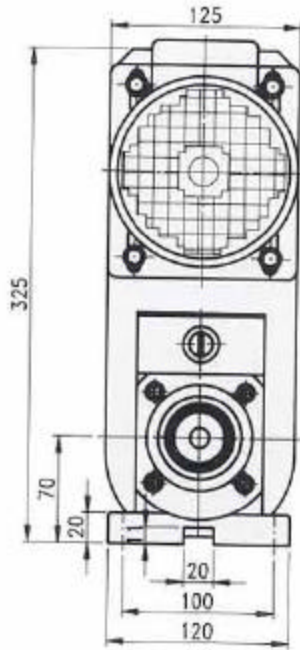

FD55-80-JT6

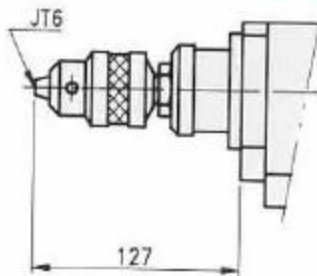

FD55-80-ER20

