



Drilling Unit FD62-100



■ Specification

| | |
|------------------------|--|
| Hydraulic Pressure | 280 ~ 350 P.S.I |
| Drilling Capacity | 5/8" (steel) |
| Power | 1HP-2P or 4P, 230V/460V |
| Stroke | 4" |
| Max. Revolution/Minute | 2,000rpm |
| Flow Control Valve | FCC-G02-4 |
| Weight | 145 lb |
| Cylinder Diameter | 3" |
| Cylinder Area | Forward 6.70 IN ² , Backward 4.75 IN ² |
| Thrust Force | 1900 lb @ 280 P.S.I |
| Transmission | a. A2-O.D.-4" |
| | b. H.T.D.-5M-62T |
| | c. Step pulley O.D.-5"-4.3"-3.5" |

■ Consumption Parts

| | |
|------------------------|---------------------------------------|
| O-Ring for Front Cover | P-58x2, G-80x2 |
| O-Ring for Piston | P-70x2, G-45x1 |
| O-Ring for Rear Cover | P-30x2, G-75x1 |
| Spindle Bearings | a. 32005x1, 6005Zx1, 32004x1, 6004Zx1 |
| | b. 7005x2, 7004x2 |
| Pulley Bearings | a. 6008Zx1, 51208x1 or 51108x1 |
| | b. 7008x2 |

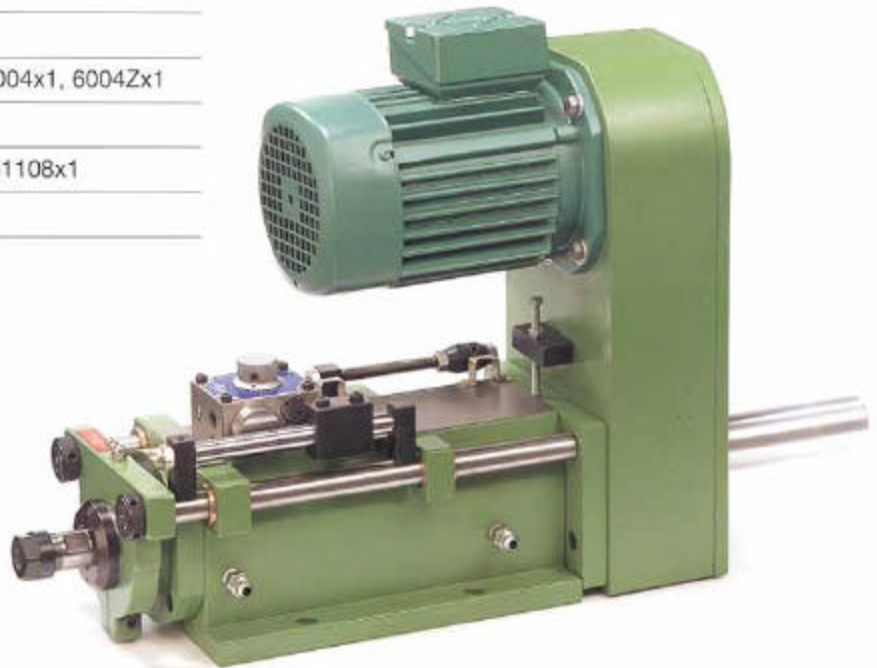

Hause Machines, Inc.
809 S. Pleasant St.
P.O. Box 229
Montpelier, OH 43543

Phone 419-485-3158
Toll Free 800-932-8665
Fax 419-485-3146
E-mail hause@bright.net
Web Page www.hausemachines.com

- High rpm application is available, specify this requirement when placing order.
- Left side mounted fitting holes and flow control valve are available, specify this requirement when placing order.
- The stopper is a safety device. It will shorten bearing life if applying pressure on stopper for a long time.



Drilling Unit FD62-100

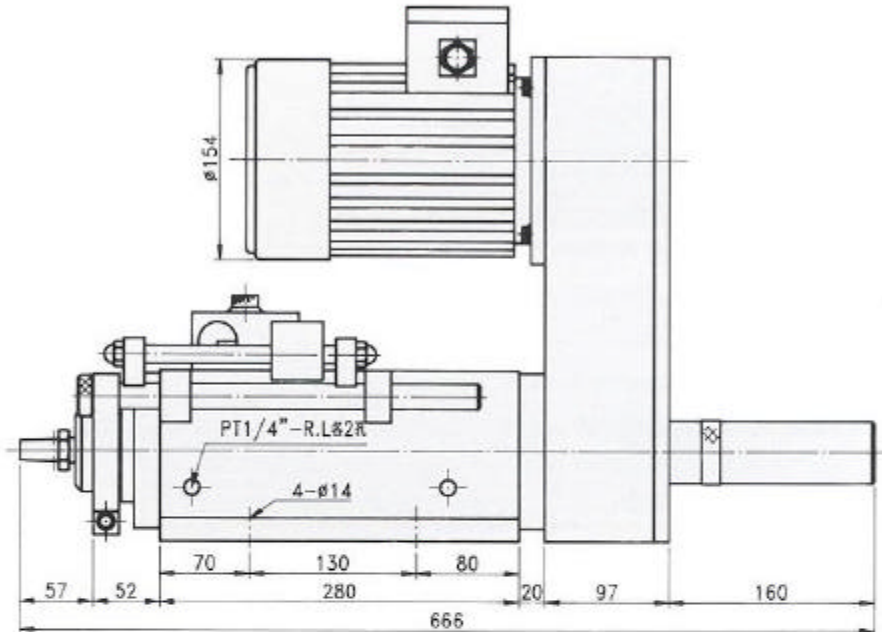
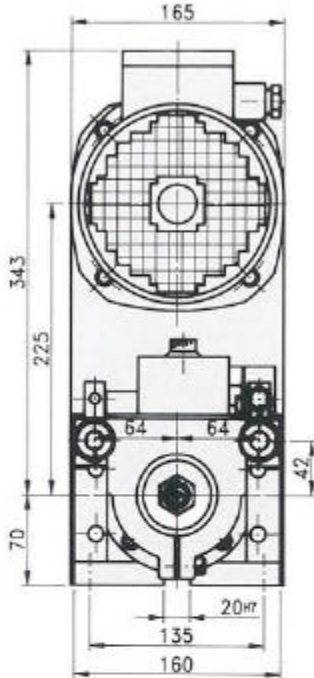

FD62-100-ER20

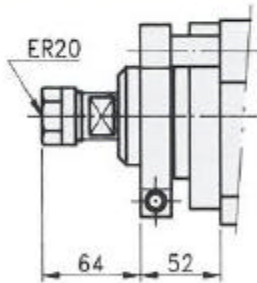

FD62-100-ER25

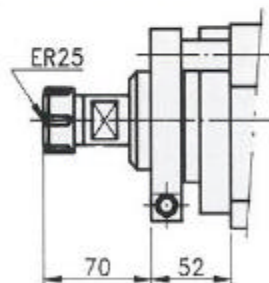

FD62-100-JT6

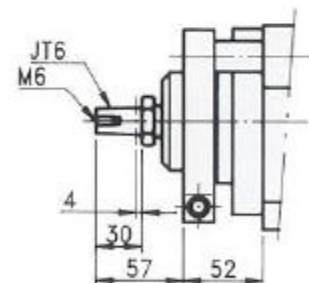

FD62M-100-JT6 Multi

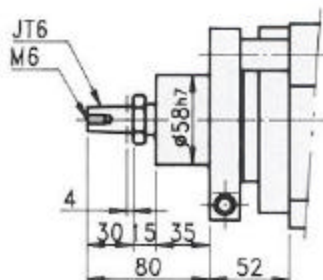

FD62-100-AS22

