



Adjustable Multiple Spindle Head



T-214
T-226



T-214
T-226



T-214
T-226
T-359

T-359



A-124
A-100

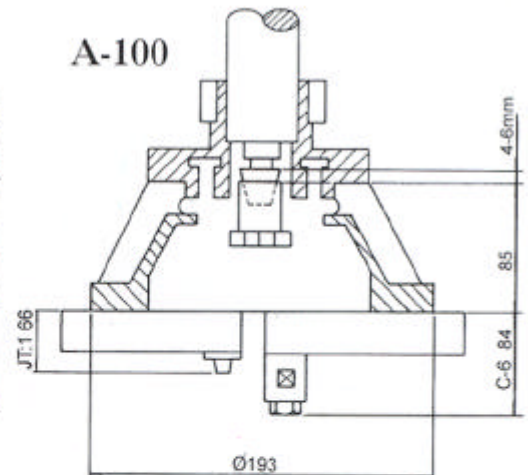
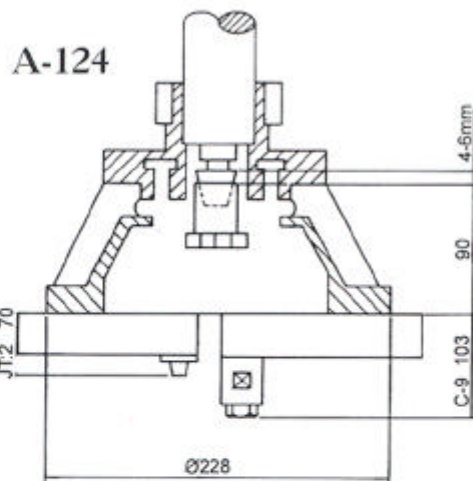
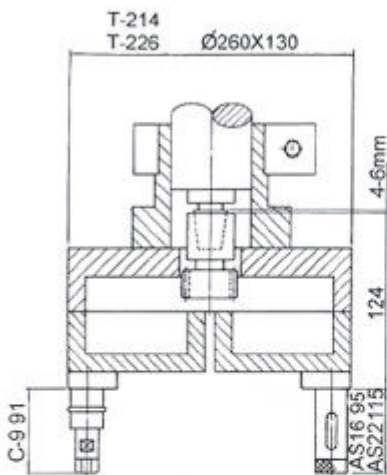

Model	A-100	A-124	D-170	D-175	D-177	D-198
Max. Distance between Spindles	100	125	170	170	177	198
Min. Spindle Diameter	25(4S)	38(4S)	38	43(3S)	55(4S)	61(4S)
Min. Distance between Spindles	18.5	27	38	38	38	43
Ratio of input/output RPM	1:1	1:1	1:2.7	1:2.7	1:3	1:2.9
Max. Drilling Capacity in Mild Steel (mm)	$\varnothing 6$	$\varnothing 8$	$\varnothing 13$	$\varnothing 13$	$\varnothing 10$	$\varnothing 13$
Max. Tapping Capacity in Mild Steel (mm)	M5	M7	M10	M10	M8	M10
Number of Spindles	2~4	2~4	2	3	4	4