



## Adjustable Multiple Spindle Head



T-72



T-108  
T-121



T-214  
T-226  
ER Type



T-214  
T-226  
Floating Adapter Type

Patent No. 79022

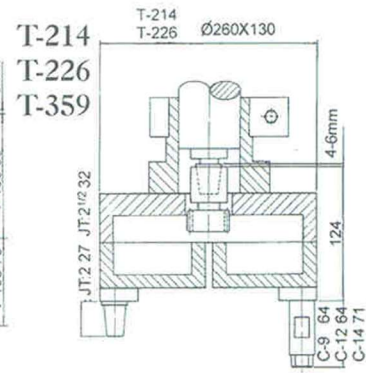
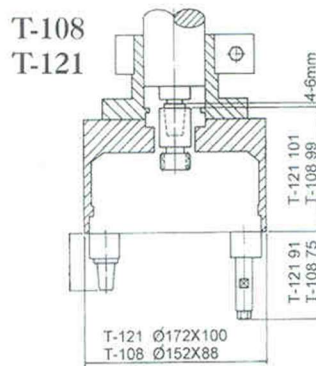
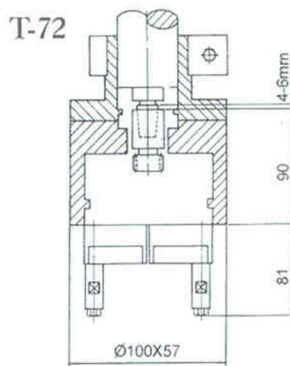

Model	T-72	T-108	T-121	T-214	T-226	T-359
Max. Distance between Spindles	72	108	121	214	226	359
Min. Spindle Diameter	12.5	18	24	45.5	33.5	56
Min. Distance between Spindles	12.5	18	24	45.5	33.5	56
Ratio of input/output RPM	1:1	1:1	1:1	1:1	1:1	1:1
Max. Drilling Capacity in Mild Steel (mm)	Ø4	Ø6	Ø8	Ø11	Ø9	Ø9
Max. Tapping Capacity in Mild Steel (mm)	M4	M6	M7	M12	M8	M8
Number of Spindles	2	2	2	2	2	2