



# Tapping Unit F2N-60



## ■ Specification

Tapping Capacity	1/4" (steel)
Chuck Capacity	ER16-3/8", JT1-1/4"
Power	0.5 HP-2P, 4P 220V/440V-60HZ
Stroke	2"
Max. RPM	1,800rpm
Weight	44 lb
Thread Pitch	100UNF ~ 24UNF
Gauge Lubrication	Grease
Transmission	V-belt, H.T.D.-5M

## ■ Consumption Parts

Spindle Bearing	NKX 17ZB x 2
Pulley Bearing	6003ZZx1, 6203ZZx1

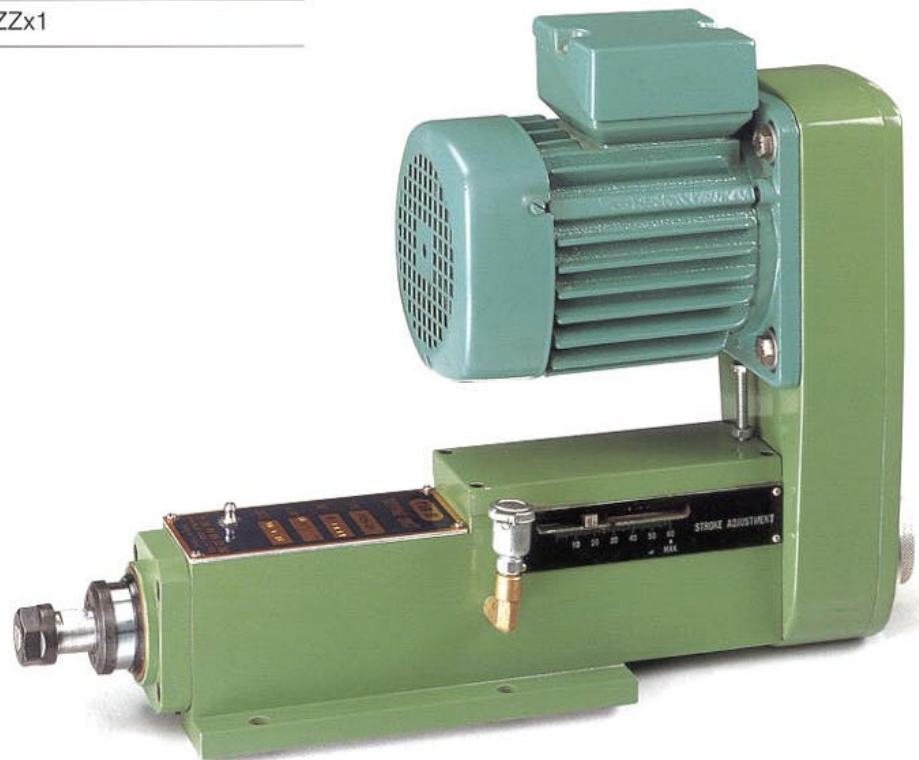

**Hause Machines, Inc.**  
**809 S. Pleasant St.**  
**P.O. Box 229**  
**Montpelier, OH 43543**

Phone 419-485-3158  
Toll Free 800-932-8665  
Fax 419-485-3146  
E-mail [hause@bright.net](mailto:hause@bright.net)  
Web Page [www.hausemachines.com](http://www.hausemachines.com)

- The unit is equipped with high precision, grinding master gauge for precision and fine tapping works.
- Thread pitch should be given when ordering.
- Master gauge is mounted internally to the unit body for application of less model change.
- Torque protection device is included for reducing tap damage.
- Motor and pulley set can be mounted around the circle with interval of 45 degree



# Tapping Unit F2N-60

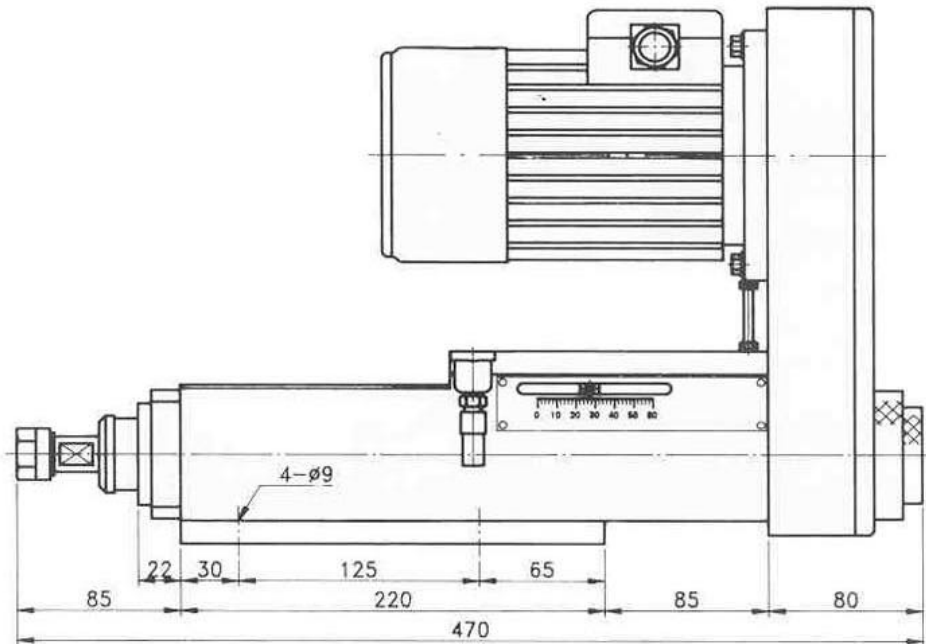
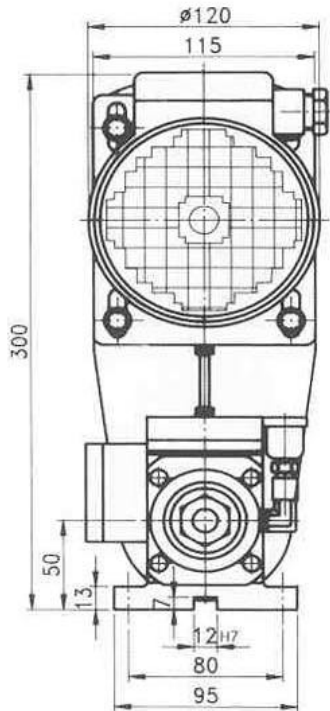

**F2N-60-JT1**

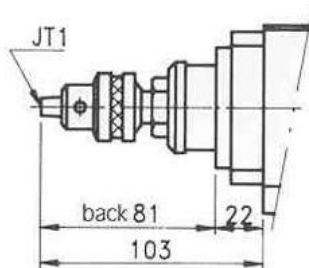

**F2N-60-ER16**

