



# Tapping Unit F7N-80



## ■ Specification

Tapping Capacity	1¼" (steel)
Stroke	3"
Thread Pitch	36UNF ~ 10UNC
Gauge Lubrication	Grease
Weight	90 lb
Transmission	a. A2-O.D-6"
	b. B2-O.D-6"
	c. H.T.D.-8M-58T
	d. RS40x2-35T

## ■ Consumption Parts

Spindle Bearing	6008Zx3
Pulley Bearing	6010Zx2, 6010LLx1
O-Ring for Spindle	TC-45, 68, 12



**Hause Machines, Inc.**  
809 S. Pleasant St.  
P.O. Box 229  
Montpelier, OH 43543

Phone 419-485-3158  
Toll Free 800-932-8665  
Fax 419-485-3146  
E-mail [hause@bright.net](mailto:hause@bright.net)  
Web Page [www.hausemachines.com](http://www.hausemachines.com)

- The unit is mounted with high precision, grinding master gauge for precision tapping works.
- Thread pitch should be given when ordering.
- Master gauge is mounted externally to the end of unit for easy and quick change.
- Horizontal and vertical application are available, oil cup should be adjusted accordingly.
- For mounting multiple spindle to this tapping unit, we recommended nose type: F7N-80-MT3B.



# Tapping Unit F7N-80

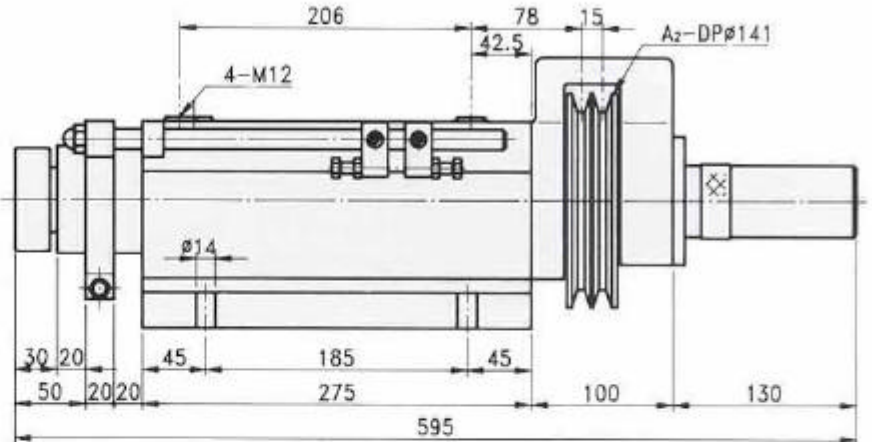
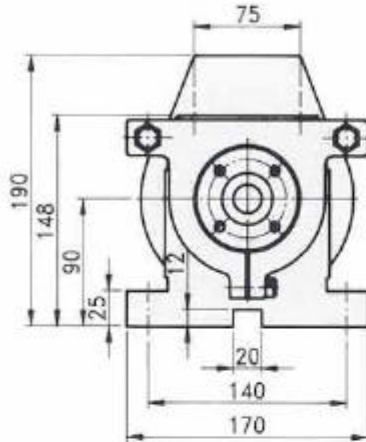

## F7N-80-AS32

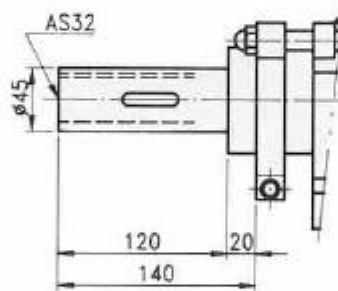

## F7N-80-FB20

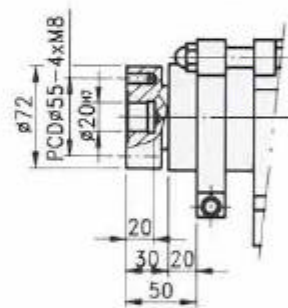

## F7N-80-MT3B

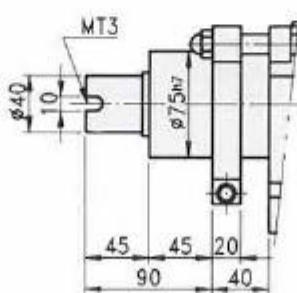

## F7N-80-NT40

