



Drilling Unit FD7-150



■ Specification

Hydraulic Pressure	280 ~ 490 P.S.I.
Drilling Capacity	1" (steel)
Stroke	5.5"
Max. Revolution/Minute	1,500rpm
Flow Control Valve	FCC-G03-8
Weight	140 lb
Cylinder Diameter	4.33"
Cylinder Area	Forward 11.0 IN ² , Backward 6.95 IN ²
Thrust Force	3124 lb @ 280 P.S.I

■ Consumption Parts

O-Ring for Front Cover	P-80x2, G-105x1, DH-80x1
O-Ring for Piston	P-100x2, G-65x1
O-Ring for Rear Cover	P-55x2, G-105x1
Spindle Bearings	32008x1, 32007x1, 6007Zx1, 6008Zx1
Pulley Bearings	6013Zx1, 51213x1



Hause Machines, Inc.
809 S. Pleasant St.
P.O. Box 229
Montpelier, OH 43543

Phone 419-485-3158
Toll Free 800-932-8665
Fax 419-485-3146
E-mail hause@bright.net
Web Page www.hausemachines.com

- The unit can be mounted on machine with its base or front end.
- Left side mounted fitting holes and flow control valve are available, specify this requirement when placing order.
- This requirement when placing order.
- The stopper is a safety device. It will shorten bearing life if applying pressure on stopper constantly.
- If mounting multiple spindle head to this unit, please choose nose type: FD7M-150MT3B.



Drilling Unit FD7-150

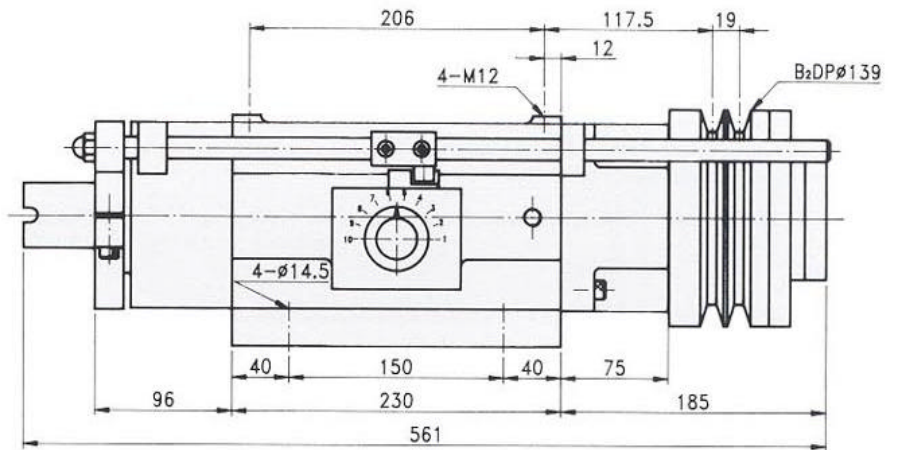
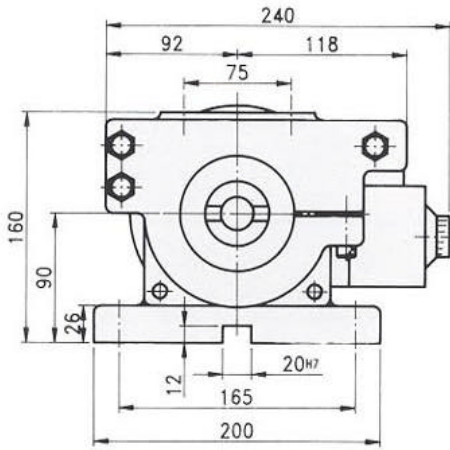

FD7-150-MT3B

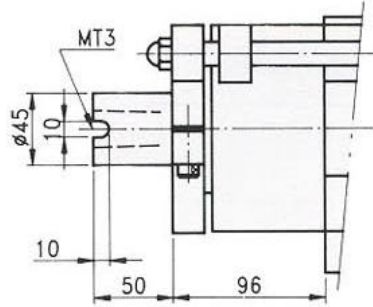

FD7M-150-MT3B Multi

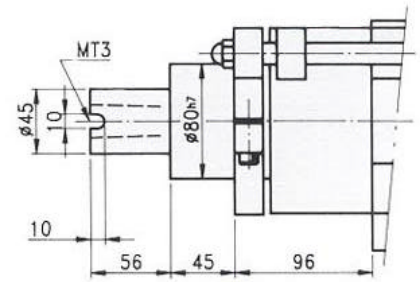

FD7-150-ER40

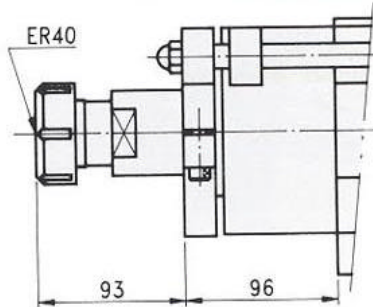

FD7-150-FB30

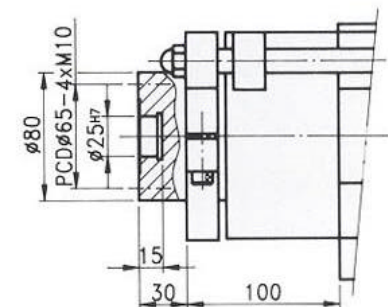

FD7-150-MT3A

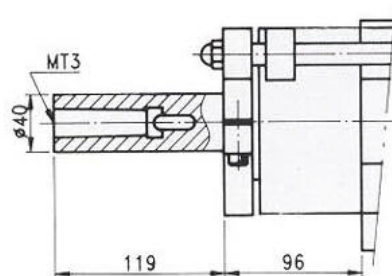

FD7-150-AS32

